

**PLANTA**

ESC: 1/20

Dado de concreto de 0.20x0.20m.

Tapon H, con perf.  $\phi 3/16''$

$\phi$ CANASTILLA	N° ORIFICIOS
2"	15
3"	20
4"	25

Orificios circulares  $\phi 3/16''$

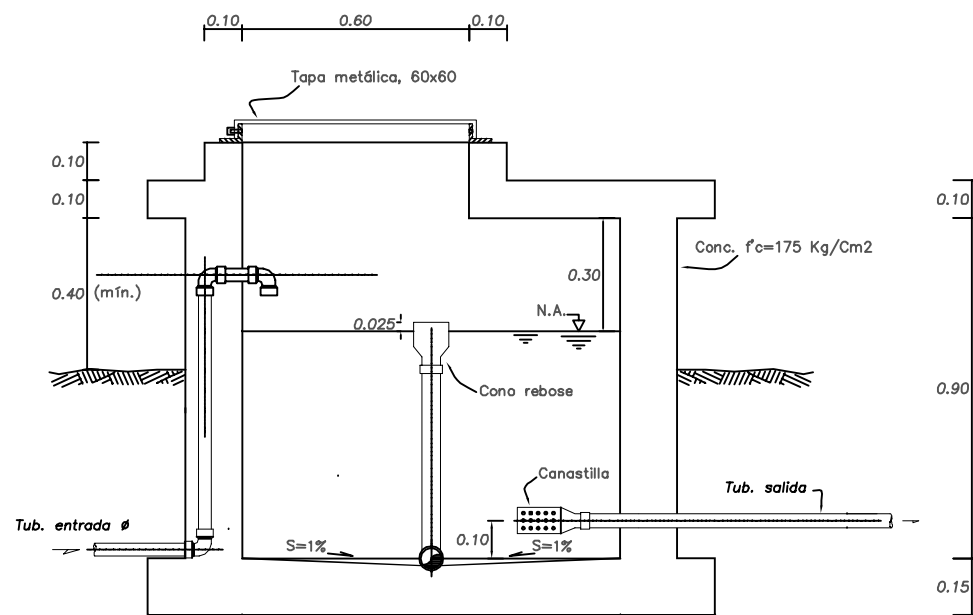

**CORTE A-A**

ESC: 1/20

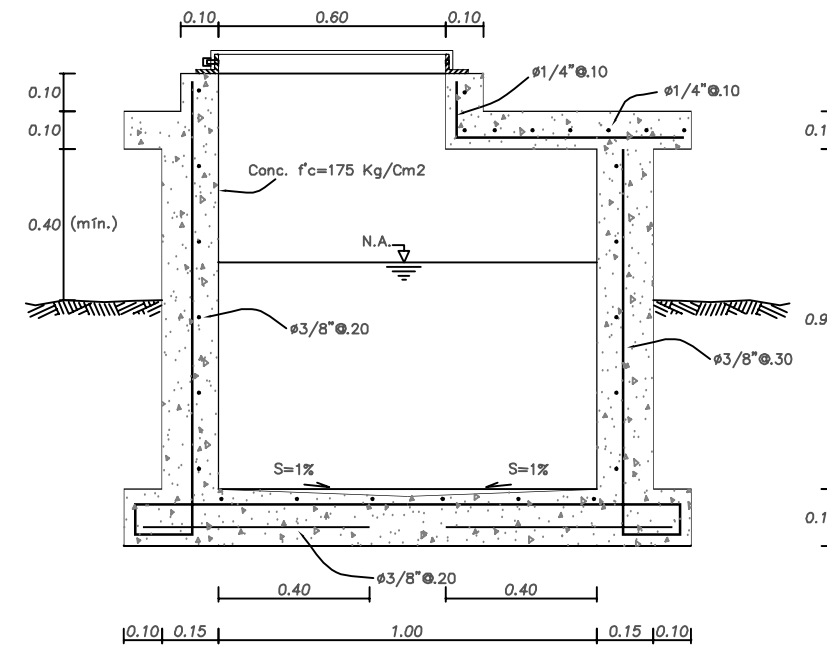

**ELEVACION**  
**DISTRIBUCION DE ARMADURA**

ESC: 1/20

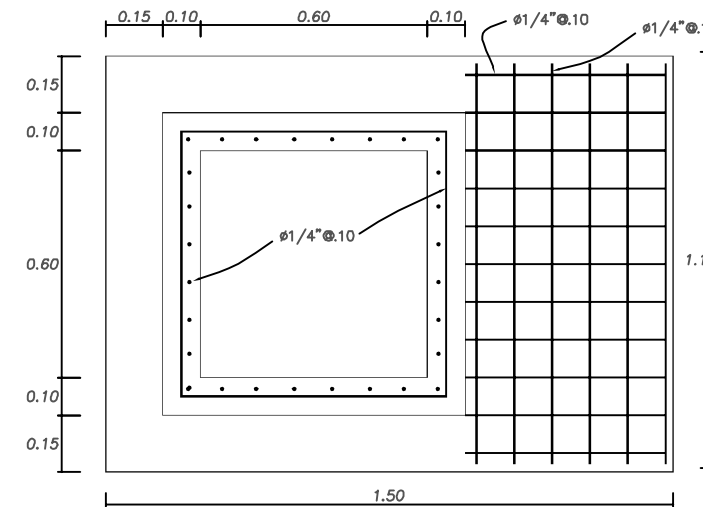

**LOSA SUPERIOR**  
**DISTRIBUCION DE ARMADURA**

ESC: 1/20



<p><b>UNIVERSIDAD NACIONAL DEL ALTIPLANO</b> ESCUELA PROFESIONAL DE INGENIERIA CIVIL</p>		<p>N° DE PLANO:</p> <h1>A-08</h1>
<p>CURSO: TESIS PARA OPTAR EL TITULO PROFESIONAL DE INGENIERO CIVIL</p>		<p>PRESENTADO POR: BACH. ING. SUNI QUISPE EDILBERTO</p>
<p>PLANO: DETALLE DE CAMARA ROMPE PRESION</p>		